

電源電圧は3~6V推奨

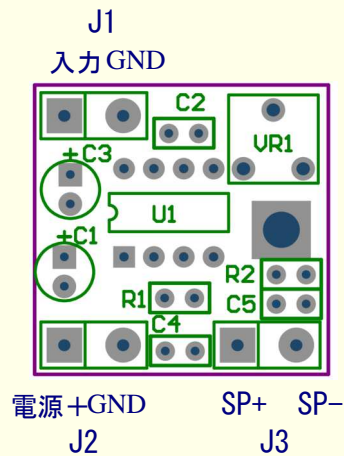

### 部品票

Used	Part Type	Designator
2	0.1uF	C4 C5
1	0.01uF	C2
2	4.7	R1 R2
1	10uF	C3
1	100uF	C1
1	TDA2822	U1
1	10K	VR1

## TDA2822 モノBTLアンプ基板

Size A4	FCSM No.	DWG No.	Rev
Scale	Sheet 0 of 0		