

## FM RECEIVER CIRCUIT FOR BATTERY SUPPLY

### DESCRIPTION

The SC1088 is a bipolar integrated circuit for use in mono portable and pocket radios. It is used when a minimum of peripheral components (of small dimensions and low costs) is important. The circuit contains a frequency-locked-loop(FLL) system with an intermediate frequency(IF) of about 70kHz. Selectivity is achieved by active RC-filters. De-tuning related to the IF and too weak input signal is suppressed by the mute circuit.

### FEATURES

- \* Equipped with all stages of a mono receiver from antenna to audio output.
- \* Mute Circuit
- \* Search tuning with a single varicap diode
- \* Mechanical tuning with integrating AFC
- \* AM application supported
- \* Power supply polarity protection
- \* Power supply voltage down to 1.8V

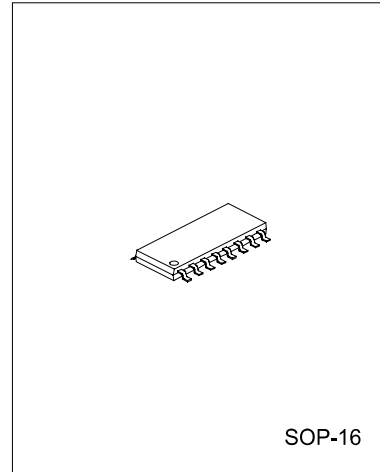

### APPLICATION

1. Mechanical tuning: This is possible with or without integrated AFC circuit
2. Electrical tuning: This is realized by one directional(band-up) search tuning facility, including RESET to the lower-band limit.

### PIN CONFIGURATIONS

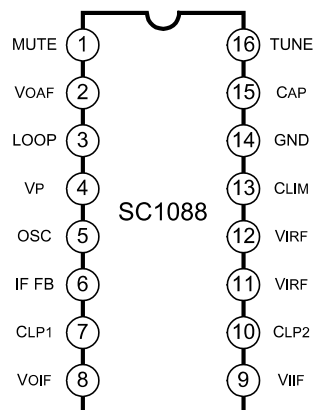

**BLOCK DIAGRAM**

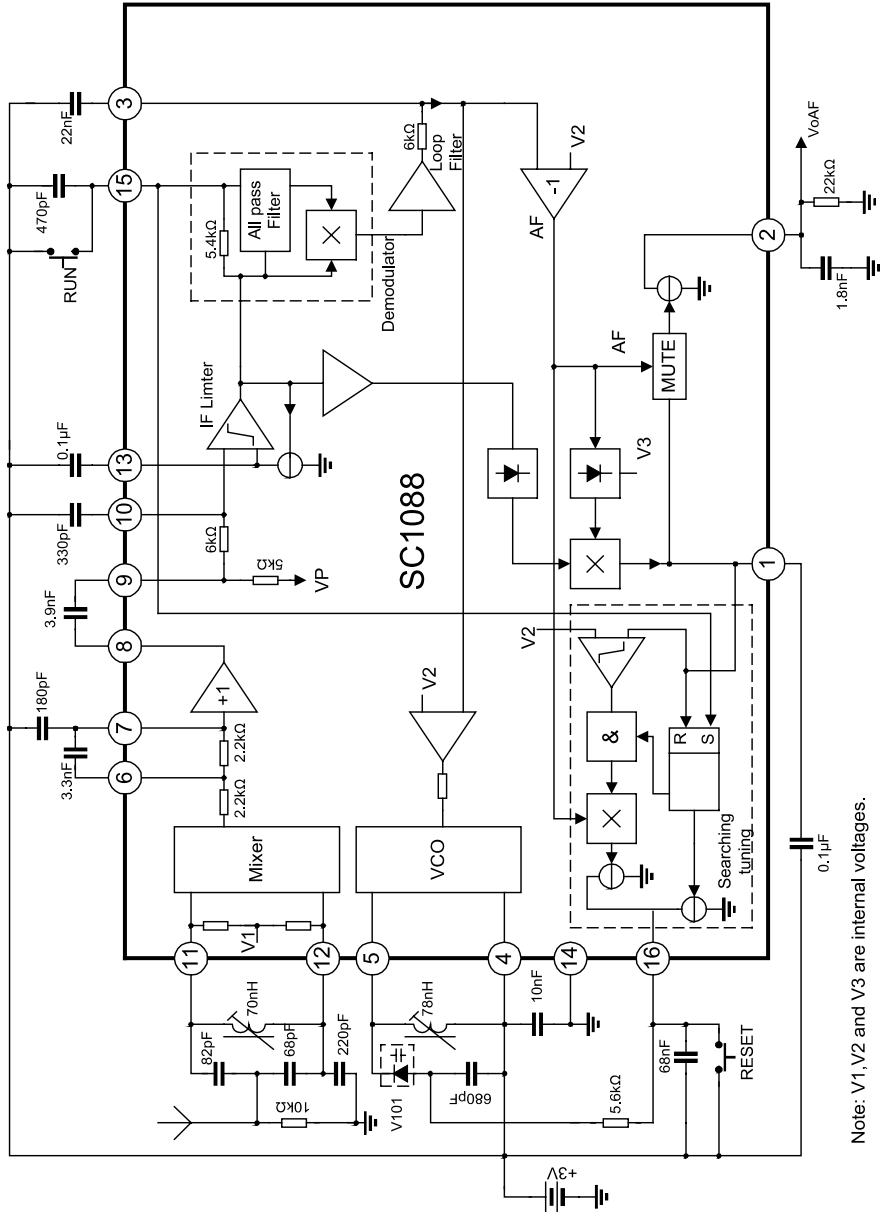

Fig.1 Block Diagram and Application Circuit for Search Tuning.

**ABSOLUTE MAXIMUM RATINGS**

Characteristic	Symbol	Value	Unit
Supply Voltage	$V_p$	5	V
Operating Temperature	$T_{amb}$	-10 ~ +70	°C
Storage Temperature	$T_{stg}$	-55 ~ +150	°C

**DC ELECTRICAL CHARACTERISTICS**

( $T_{amb}=25^{\circ}\text{C}$ ,  $V_p=3\text{V}$ , Unless otherwise specified)

Parameter	Symbol	Test conditions	Min	Typ	Max	Unit
Supply Voltage(pin 4)	$V_p$		1.8	3.0	5.0	V
Supply Current(Pin 4)	$I_p$		4.2	5.2	6.6	mA
DC voltage of pin 1	$V_1$		2.50	2.55	2.60	V
DC voltage of pin 3	$V_3$		2.64	2.69	2.74	V
DC voltage of pin 6 and 7	$V_{6,7}$		2.38	2.44	2.50	V
DC voltage of pin 8	$V_8$		1.60	1.67	1.74	V
DC voltage of pin 9,10 and 13	$V_{9,10,13}$		2.42	2.47	2.52	V
DC voltage of pin 11 and 12	$V_{11,12}$		0.91	0.94	0.98	V
DC voltage of pin 15	$V_{15}$		2.06	2.12	2.18	V
AF output current on pin 2	$I_2$		45	60	80	$\mu\text{A}$
Oscillator current on pin 5	$I_5$		275	375	500	$\mu\text{A}$

**AC ELECTRICAL CHARACTERISTICS**

$T_{amb}=25^{\circ}\text{C}$ ,  $V_p=3\text{V}$ ,  $f_{irf}=96\text{MHz}$  modulated with  $\Delta f=\pm 22.5\text{kHz}$  and  $f_m=1\text{kHz}$  deviation;  $EMF=0.3\text{mV}$ (e.m.f. at a source impedance of  $75\Omega$ ), and measurement taken in fig.3 Unless otherwise specified

Parameter	Symbol	Test conditions	Min	Typ	Max	Unit
RF Sensitivity input voltage	$V_i(\text{rms})$	$V_{oAF}=-3\text{dB}$ ; $V_{oAF}=0\text{dB}$ at $V_i=1\text{mV}$ ; see Fig. 2				
		Mute OFF		3	6	$\mu\text{V}$
		Mute ON	3	6	12	$\mu\text{V}$
		( $S+N$ )/ $N=26\text{dB}$		5	10	$\mu\text{V}$
Signal handling		THD<10%, $\Delta f=\pm 75\text{kHz}$	100	200	—	mV
Signal-to -noise ratio	( $S+N$ )/ $N$	See fig.2	52	56	—	dB
Total Harmonic distortion	THD	$\Delta f=\pm 22.5\text{kHz}$	—	1	1.4	%
		$\Delta f=\pm 75\text{kHz}$		2.4	3.3	%
AM suppression of output voltage	AMS	FM: 1kHz; $\pm 75\text{kHz}$ AM: 1kHz; MOD=80%	47	52		dB
Ripple rejection	RR	$\Delta V_p=100\text{mV}_{\text{rms}}$ , $f=1\text{kHz}$	7	10		dB
Audio output signal	$V_o(\text{rms})$	$R_L=22\text{k}\Omega$	60	85	120	mV
<b>Search Tuning(with V101 and C16=0.1<math>\mu\text{F}</math>) See Fig.1</b>						
Minimum output voltage on pin 16	$V_{16}$	Limiting point		$V_p-1.85$		V
Tuning steepness	$\Delta V/\Delta t$	Voltage at pin 16	95	210	420	mV/sec
Oscillator steepness	$\Delta f_{osc}/\Delta t$		1.25	2.83	5.6	MHz/sec
AFC steepness	$\Delta I_{AFC}/\Delta V_3$	Voltage at pin 3	4.75	9.5	19	$\mu\text{s}$

**PIN DESCRIPTIONS**

Pin No.	Symbol	Description	Pin No.	Symbol	Description
1	MUTE	Mute output	9	V <sub>IF</sub>	IF input to limiter amplifier
2	VOAF	Audio frequency output signal	10	CLP2	Low-pass capacitor of IF limiter amplifier
3	LOOP	AF loop filter	11	V <sub>IRF</sub>	Radio frequency input
4	V <sub>p</sub>	Supply voltage	12	V <sub>IRF</sub>	Radio frequency input
5	OSC	Oscillator resonat circuit	13	CLIM	Limiter offset voltage capacitor
6	IF FB	IF feedback	14	GND	Ground
7	CLP1	Low-pass capacitor of 1dB amplifier	15	CAP	All-pass filter capacitor,input for search tuning
8	VOIF	IF output to external coupling capacitor(high-pass)	16	TUNE	Electrical tuning/AFC output

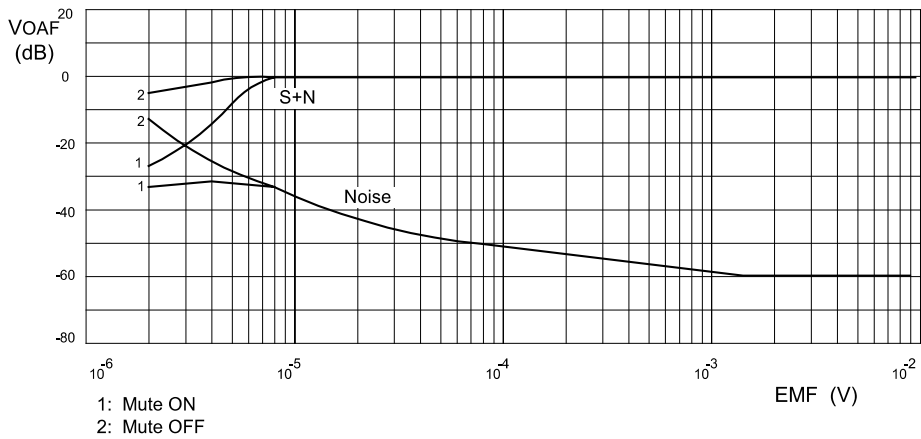

Fig. 2 Input sensitivity

**TEST AND APPLICATION CIRCUIT**

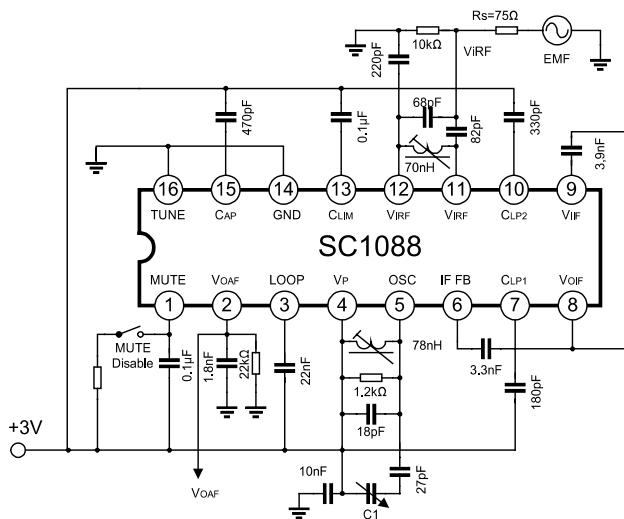

Fig. 3 Test circuit and application for mechanical tuning

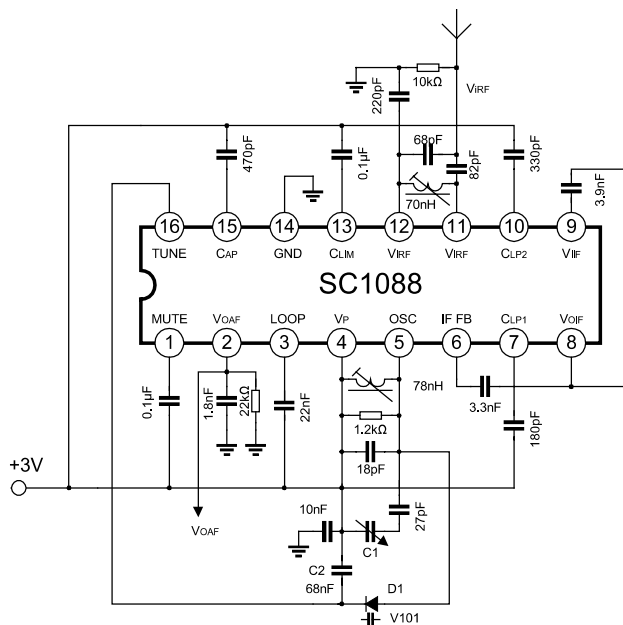

Fig. 4 Application circuit with AFC for mechanical tuning

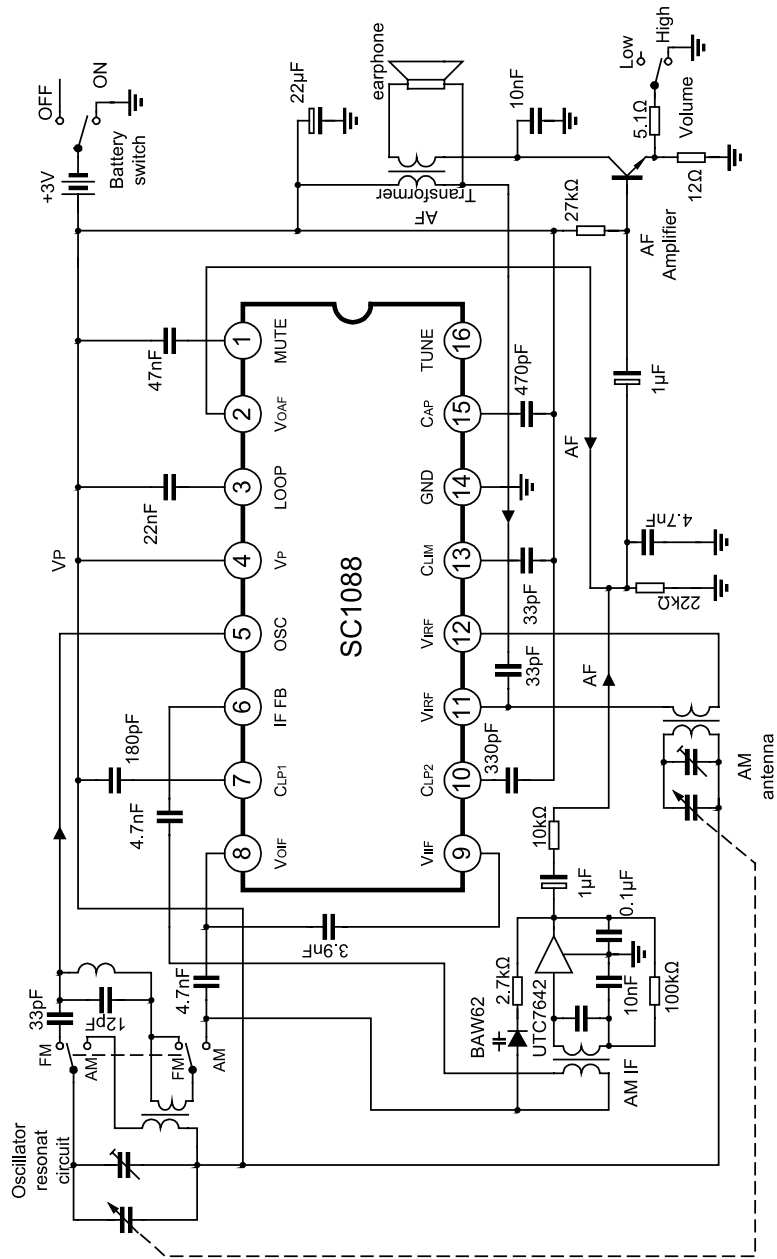

Fig.5 AM application circuit

**PACKAGE OUTLINE**

